

YAGI QWL 4 elementi banda 8m by I3RKE

Forward Gain: 10,38 dBi @ 40,680 MHz
 Front/Back Ratio: 42 dB @ 40,680 MHz
 Peak Gain: 10,38 dBi
 Front/Side ratio: 21 dB
 VSWR: <1,3:1 da 40,54 MHz a 40,75 MHz

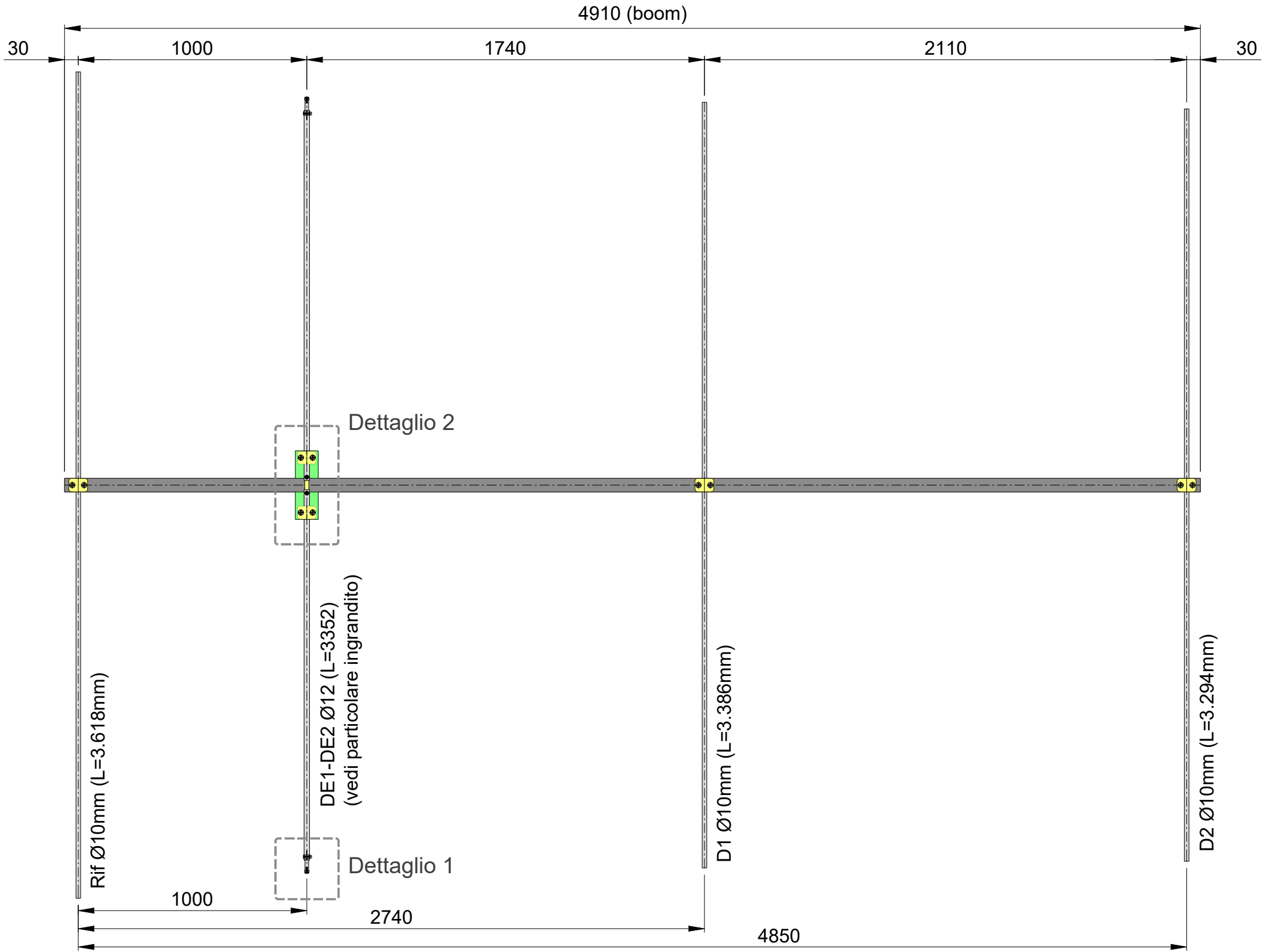

Particolare del dipolo ripiegato

~ 3352 (da regolare per il miglior SWR)

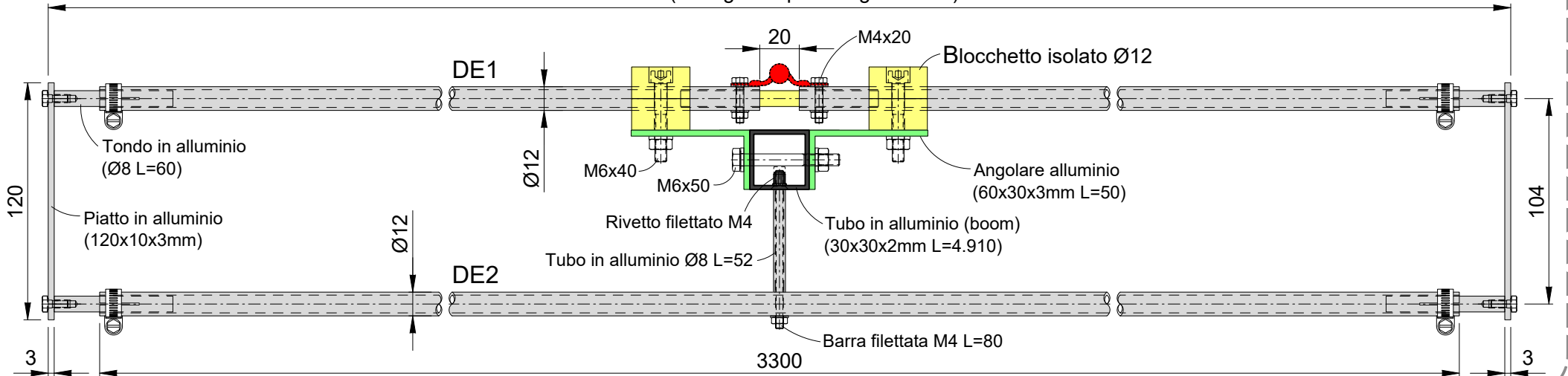

Dettaglio 1

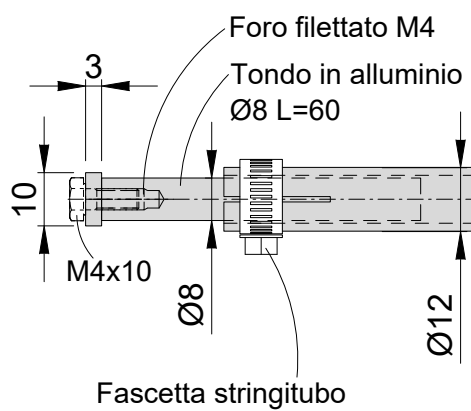

Dettaglio 2

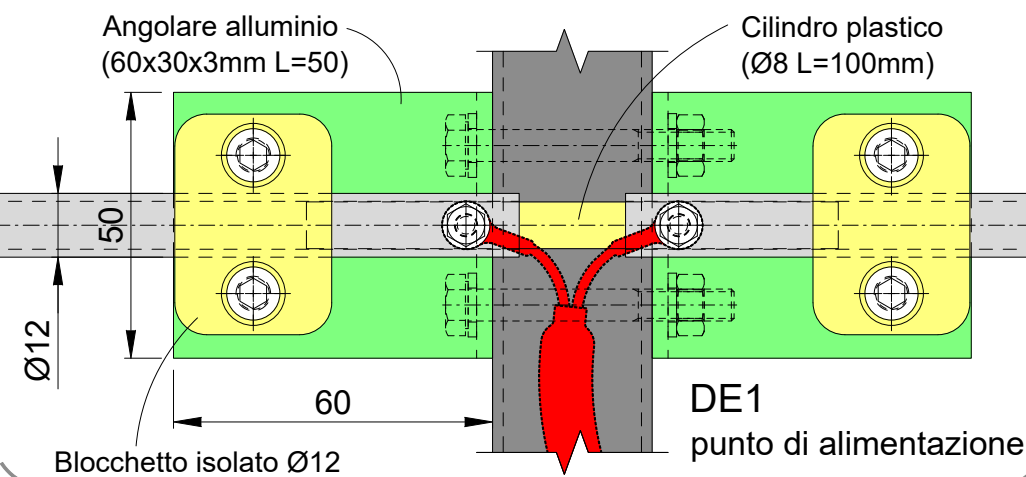

Fissaggio Rif, D1 e D2

